

ENTERPRISE ARCHITECTURE – FRAMEWORK AND METHODOLOGY FOR THE DESIGN OF ARCHITECTURES IN THE LARGE

Michael Rohloff, Siemens AG, Corporate Information Office, Business Administration
CIO BA PMT; Processes, Methods & Tools,
Südallee 1, 85356 Munich Airport, michael.rohloff@siemens.com

Abstract

The paper outlines the domains of enterprise architecture and basic requirements of “architectures in the large”. A methodology for the description of enterprise architectures is introduced. It is based on three basic views on architecture. The component view describes the elements of architecture and their relationships. The communication view shows how the elements interact with one another. The distribution view describes how the elements are distributed in terms of location or organizational assignment. Based on the three basic views on architecture, complexity can be reduced and elementary construction principles of the architecture can be highlighted.

Key element of architecture design is to account for interdependencies among the building blocks of architecture. Blueprints are introduced as a means in planning the deployment of architecture on a large scale. Blueprints give a comprehensive view on the building blocks and how they interact. They show the effects of architecture design between business, application, and infrastructure architecture.

The techniques introduced for architecture design are illustrated by using a selection of real life examples from an architecture design project at Siemens AG.

Keywords: enterprise architecture, architecture design process, architecture management, business architecture, application architecture, infrastructure architecture, architecture views, blue prints.

1 REQUIREMENTS FOR MANAGEMENT AND DEVELOPMENT OF ENTERPRISE ARCHITECTURES

The Encyclopedia Britannica defines architecture as the art and technique of designing and building, as distinguished from the skills associated with construction. The practice of architecture is employed to fulfill both practical and expressive requirements of civilized people and thus embraces both utilitarian and aesthetic ends. Although these two ends may be distinguished, they cannot be separated. Basically there are three main characteristics that make a good architecture: firmitas (firmness, structural soundness), utilitas (commodity, usefulness), venustas (grace, elegance) (Encyclopedia Britannica 1978).

Architecture is of Greek origin and defines the discipline of construction and design of buildings. The definition of the Encyclopedia Britannica shows that architecture must be driven by the requirements and that it must be durable, flexible and that certain elegance must be fulfilled.

Architecture is a commonly used term in the design of information systems. However, it is used very differently in scope ranging from the architecture of computer systems to information systems architecture (see Aranow 2002, Becker/ Schütte 2004, p. 271, Birckhäuser/ Vaupel 2003, p. 18-20, Krcmar 2005, p. 44, Krcmar 1990, Sinz 1997, 2002).

IEEE Standard 1471-2000 defines architecture as „... the fundamental organization of a system, embodied in its components, their relationships to each other and the environment, and the principles governing its design and evolution” (IEEE 2000). We summarize the understanding of architecture in “architecture is the art and practice of designing and building structures”.

Enterprise Architecture comprises the entire business with all its constituents. The alignment of the business and organizational design of the enterprise with the IT architecture is fundamental. However understanding and structuring of the basic elements differs. For different viewpoint on Enterprise architecture see Buhl and Heinrich (2004).

In contrast to information systems architecture, which was widely discussed under the aspect of a single information system being integrated in organization and aligned with business process, enterprise architecture takes the entire IT landscape in focus. In comparison architecture is understood as city planning and not only as planning the architecture of a house (Gartner 2002). An “architecture in the large” requires the definition of development plans for an entire area and not only the construction plan for a building.

The listing sketches some objectives to be pursued with enterprise architecture (Günzel/ Rohloff 2003, p. 424):

- Strategy and business orientation
 - enabling, leverage of IT, new business models
- Transparency
 - complexity and dependencies of architecture building block
- Communication between business and IT community
 - heterogeneous composition of people involved (from management to IT experts)
- Planning
 - target oriented, steering of I&C program with strong impact and to secure compliance to corporate standards
- Synergies
 - develop & implement the I&C landscape in a systematic manner and to utilize synergies
- Adaptability
 - dynamic development of market, business, and technology, provide for scalability and growth

Enterprise Architecture is a means to support business and IT alignment. Architecture planning is the ground for the development of the IT landscape and at the same time provides the agility to react fast to market requirements.

The following summarizes essential requirements of “architectures in the large” and challenges the development of an enterprise architecture methodology (compare Dern 2003, p. 81-83):

- Reduction to core entities and construction principles
- Balance of abstraction and specialization
- Representation of mutual dependencies
- Integration of architecture in the large and in the small

We will address these issues and show how an architecture framework and three distinct views on architecture support the reduction to core entities and construction principles. Blueprints give overview on the IT landscape and show interdependencies between the building blocks of architecture. Views and blueprints can be combined for large and small scale architecture development.

2 FRAMEWORK FOR ENTERPRISE ARCHITECTURE

2.1 Overview and Domains of Enterprise Architecture

The wide range of different domains and scope of enterprise architecture and its high complexity are characteristics of enterprise architecture. In the following a framework is introduced which structures enterprise architecture in key domains and building blocks in order to give a comprehensive view on all relevant aspects of enterprise architecture (for an overview on other enterprise architecture frameworks see Lapkin 2004a and b).

Comparing different classifications for enterprise architecture, naming and structuring of architecture domains differ, but the following key domains can be identified: the business -, information system -, and technology architecture (The Open Group Architecture framework, TOGAF 2003. META Group 2002 for example defines information architecture as a separate architecture; see also Foegen and Battenfeld 2001). The architecture framework introduced in this paper follows the basic structuring of TOGAF and details the domains in architecture building blocks to give a comprehensive overview of all constituents of enterprise architecture (figure 1). The three basic domains of the enterprise architecture framework introduced in this paper are defined as:

- Business Architecture
- Application Architecture
- Infrastructure Architecture

With this architecture definition in mind, it should be obvious that Enterprise Architecture is more than the collection of the constituent architectures. The interrelationships among these architectures, and their joint properties, are essential to the enterprise architecture.

2.2 Enterprise Architecture Framework

The *business architecture* describes the fundamental organisation and requirements of the business based on business strategy and objectives. It is composed of the four building blocks business model, organizational architecture, process architecture, and information architecture.

The business model gives a high level view on the nature of the business in terms of products & services offered in the market, the value chain, business partners, market channels utilized, and the combination of resources and information for generating value add.

The organizational architecture describes the organizational design of the enterprise and the principal cooperation with customers and suppliers.

The process architecture classifies and describes all processes of the business and their respective value adds. It is the core building block of the business architecture. Within Siemens a reference process house was developed which describes a standardized process architecture across Siemens (Siemens RPH 2004). The process architecture is classified in the core business processes customer relationship management, supply chain management, product life cycle management and the management and support processes.

The information architecture shows the logical structure of all information entities like products, business partners, logistic information etc.

The *application architecture* gives an overview on all applications supporting the processes of the business with the building blocks enterprise applications, portal & information management platform, data repositories, and EAI Services.

Enterprise applications are supporting the automation of business processes and can be assigned to the respective process in terms of their functional support.

The portal and information management platform is the universal access to all company information and knowledge. Portals are designed to specific user groups like customer, business partner, and employees.

Data repositories are the physical storage of all relevant company data and provide an integrated view on product -, customer and business partner -, logistic -, or financial data.

Enterprise application integration services provide the integration of applications and data across the company. Integration technology spans from message exchange, data exchange to process integration.

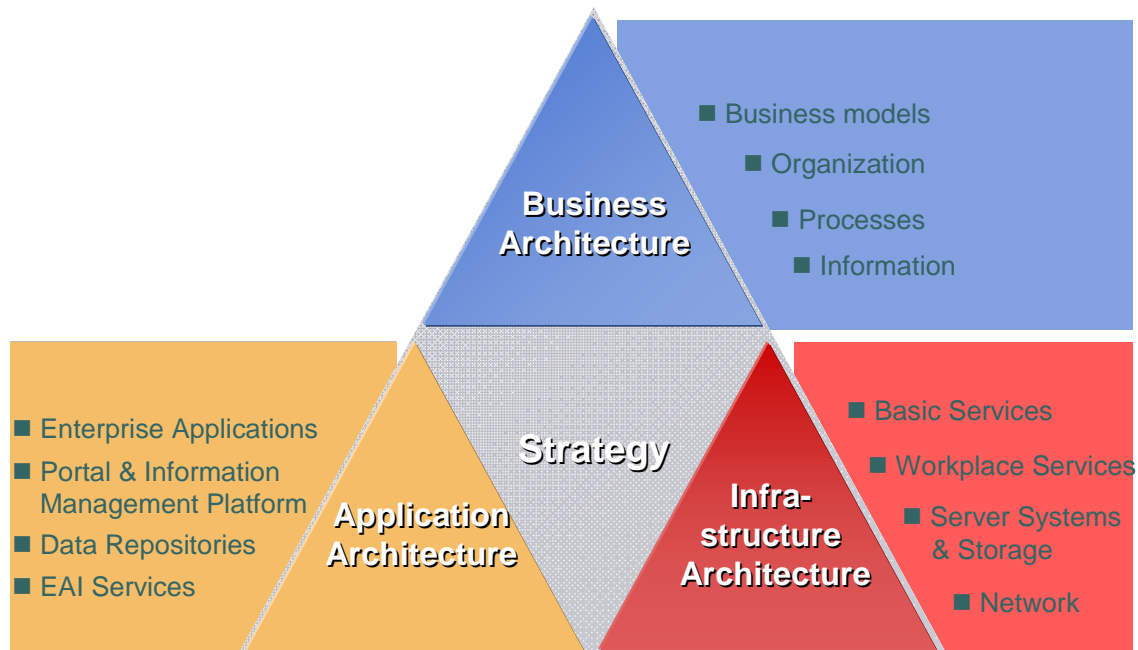

Figure 1: Enterprise Architecture Framework

The *infrastructure architecture*, also referred to as technology architecture, comprises the software, hardware and network infrastructure required for operations of all applications. Infrastructure building blocks are basic services, workplace services, server systems & storage, and the network.

Basic services are essential applications providing a specific functional support which are independent from business processes. Examples are communication services like Email or Telco, directory or search services, and administration services like single sign on or PKI. Web Services are emerging services which transfer the concept of basic service to the internet. Basic services are modules to be used in different applications.

Workplace services provide for presentation and work with information and for productivity support at the work place (office desk, shop floor etc.). They comprise fixed and mobile devices at the client site and include basic office applications and browser.

Server systems support all back end resources like applications, data repositories, integration services etc. Storage provides all memory capacity for running the applications on the server.

Networks provide the communication links in the LAN and WAN, within the company, between companies and in the Internet.

Security is integral part of all architecture building blocks and described in an overlaying structure.

This paper can only give an outline on the domains of the enterprise architecture framework and sketch the main building blocks at a high level. All building blocks of the framework are detailed down to the level of modules, systems and components. The framework gives a comprehensive description of all relevant elements of enterprise architecture providing a principal structure and classification schema used as a reference for architecture development.

An Enterprise Architecture however, includes not only the three domains for the “as is” architecture (baseline architecture) and the target architecture. It includes also a strategic information base with a clear definition of business objectives and strategy. The strategy is needed for the transitional processes in order to implement new technologies in response to the changing business needs. That means the enterprise architecture includes also the process to create, update and manage the evolution of the architecture domains in line with business strategy. Along this line architecture design of all building blocks should follow the following objectives and principles (compare Masak 2005, p. 14 f.; META Group 2002, p. 9):

Flexibility

- Open and standard based architecture
- Modular, component based approach

Adaptability

- Reuseable solutions
- Scalability of building blocks

Reliability

- Facilitates completeness & quality assurance
- Availability based on defined service levels

3 VIEWS ON ENTERPRISE ARCHITECTURE

3.1 Architecture description

An architecture description is a formal description of a system, organized in a way that supports reasoning about the structural properties of the system. It defines the building blocks and components that make up the overall system, and provides a plan from which products can be procured, and systems developed, that will work together to implement the overall system.

The IEEE-Standard “Recommended Practice for Architectural Description of Software Intensive Systems” (IEEE 2000) can be used as a basis for an architecture description. Figure 2 shows the basic understanding described in this standard: every system has an architecture, which can be recorded by an architectural description. The architectural description is organized into one or more constituents called (architectural) views. Each view addresses one or more of the concerns of the system stakeholders. The term view is used to refer to the expression of a system’s architecture with respect to a particular viewpoint.

Basically, a system has one or more stakeholders. Each stakeholder typically has interests in, or concerns relative to, that system. Concerns are those interests which pertain to the system’s development, its operation or any other aspects that are critical or otherwise important to one or more stakeholders. Concerns include system considerations such as performance, reliability, security, distribution, and ability to evolve. A system exists to fulfil one or more missions in its environment. A mission is a use or operation for which a system is intended by one or more stakeholders to meet some set of objectives.

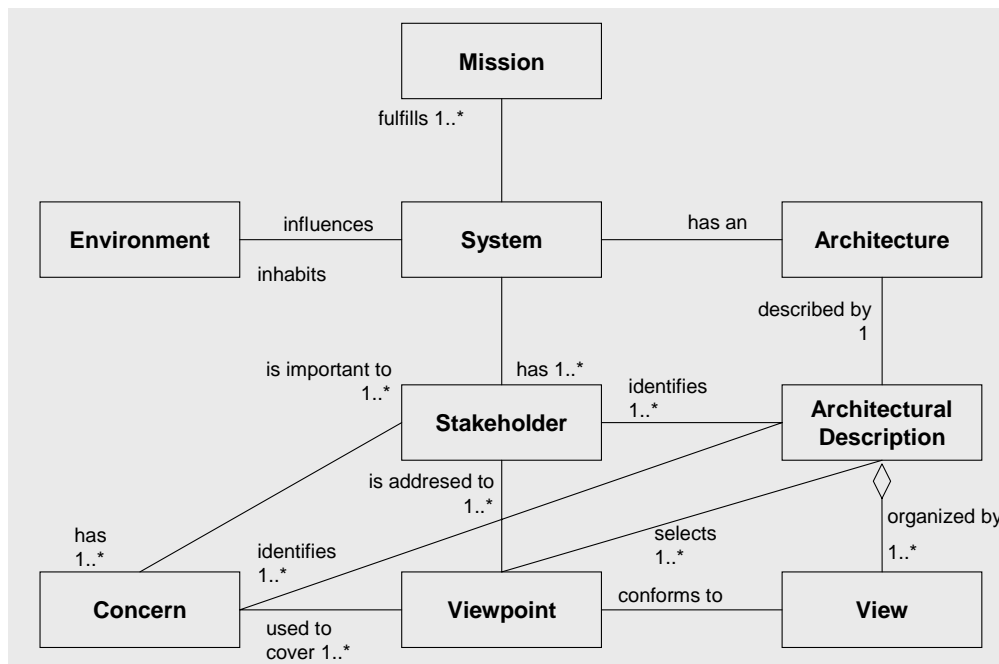

Figure 2: The conceptual model of an architectural description (IEEE 2000)

3.2 Views on architecture

The principle of views is the basis of every reasonable architecture description and the need for multiple views in architecture descriptions is widely recognized in the literature. The IEEE standard 1471 (IEEE 2000), however, describes only the concept of views, stakeholders and concerns. Because of the wide range of opinions on selecting appropriate views, the standard does not make any statements on selecting views, the notation or name of views.

There exists a variety of views in different architecture frameworks. Data-, function-, process oriented views, and dynamic aspects are often named, sometimes supplemented by an organizational and resource view (e.g. AMICE 1994, Martin/ Leben 1989, Österle 1995, Scheer 1999). Zachman (1987, p. 291) was one of the first to state “There is not an information architecture but a set of them” and he introduced different views on architecture. This work was continued over the years (Sowa/ Zachmann 1992, Zachman framework). It comprises 30 views in a 6 x 5 (or 36 in a 6 x 6) matrix with data, function, network, people, time, and motivation in scope from planning to implemented architecture. The main drawback of the Zachman framework is the fact that there are too many views included in it, which makes it difficult to implement. Not all views are described in detail and the relationship between the different views is not in all cases transparent. The framework is a mix of views, domains of enterprise architecture, and different stakeholders.

Taking a close look on the diversity of views we identified three basic views which are sufficient to describe all relevant aspects of enterprise architectures:

Component view: The view describes the logical and functional structure of the architecture in scope. All building blocks and their systems and components are described in terms of composition, structure and relationships among one another. The component view allows for different level of detail of the architecture. Components, systems, subsystems, building blocks can be grouped or decomposed. The segmentation of the diagram is in building blocks based on the respective architecture in scope.

Communication view: The view describes the communication (interaction) between systems and components. The relationship among the systems is decomposed in the interaction of components within a system and to other systems. Different types of communication can be described with distinct notation for communication lines. The segmentation of the diagram is in communication areas based on the respective architecture in scope.

Distribution view: The view describes the allocation of systems or components in terms of geographical or organizational distribution. The diagram is segmented in organization or location based on the respective architecture in scope.

Component View

Segmentation in building blocks

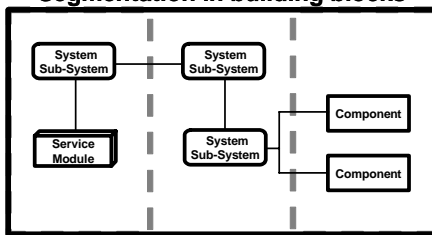

Providing information regarding the hierarchy/ functional composition of Components, Sub-Systems and Systems.

Providing as well information about function calls to associated Service Modules.

Communication View

Segmentation in communication areas

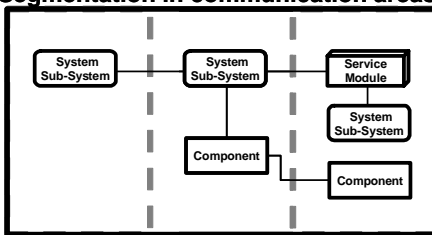

Providing information of the principal communication/ interaction between Systems and associated Service Modules across communication lines and areas.

Distribution View

Segmentation in organization/ location

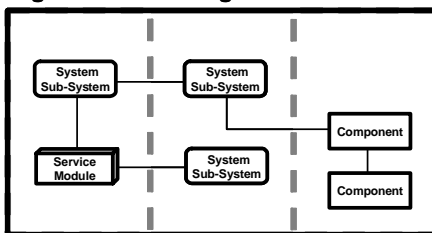

Providing information about the geographical/organizational distribution of Systems.

The allowed entities in the respective view are underlined.

Figure 3: Three views on Architecture

Figure 3 gives an overview which illustrates the basic look of these views. An aggregated view on architecture is required which goes beyond the semantics of modeling techniques like UML, thus a notation specific for the purpose of architecture design has been developed (see section 3.3 for more details).

Matthes and Wittenburg (2004) take a comparable approach in applying the discipline of cartography to the description and design of application landscapes in order to picture a number of information systems (see next section how this work relates to the blueprints).

These three views can be applied to all domains of enterprise architecture. However, the segmentation of the diagram is selected according to the appropriate context of the domain and chosen level of detail. In the following section we illustrate the use of the views for the domain of infrastructure architecture using the example of an Email Service.

The high complexity of enterprise architectures can be reduced by taking particular views which focus on specific aspects of architecture. The three views facilitate the reduction to core entities and construction principles and the understanding of their behavior.

One objective among others in the description of architecture is to identify pattern in order to establish standards for the design of architecture (Buschmann et al. 1996). These standards can be derived from these views for components, communication or distribution.

3.3 Examples for the three views

For the design of architecture a “Service Oriented Architecture” (SOA) approach is followed (for an overview on SOA see Krcmar 2005, p. 274 f., Masak 2005, p. 125 f.) Basically, IT Architecture can be always seen as providing services to the business e.g. an application supporting a business process, office and communication services at the workplace supporting each individual employee. Taking these perspective puts the value add of IT in the focus. Consequently the building blocks of the architecture framework are structured in service groups, core services, and service modules.

In the following we use the example of an Email Service to demonstrate the description of this service using the three views. It is not only to show how these views describe the Email Service in all its aspects but also to outline the notation and features of these views in light of infrastructure architecture description.

Figure 4 gives an extract of the notation of the essential elements.

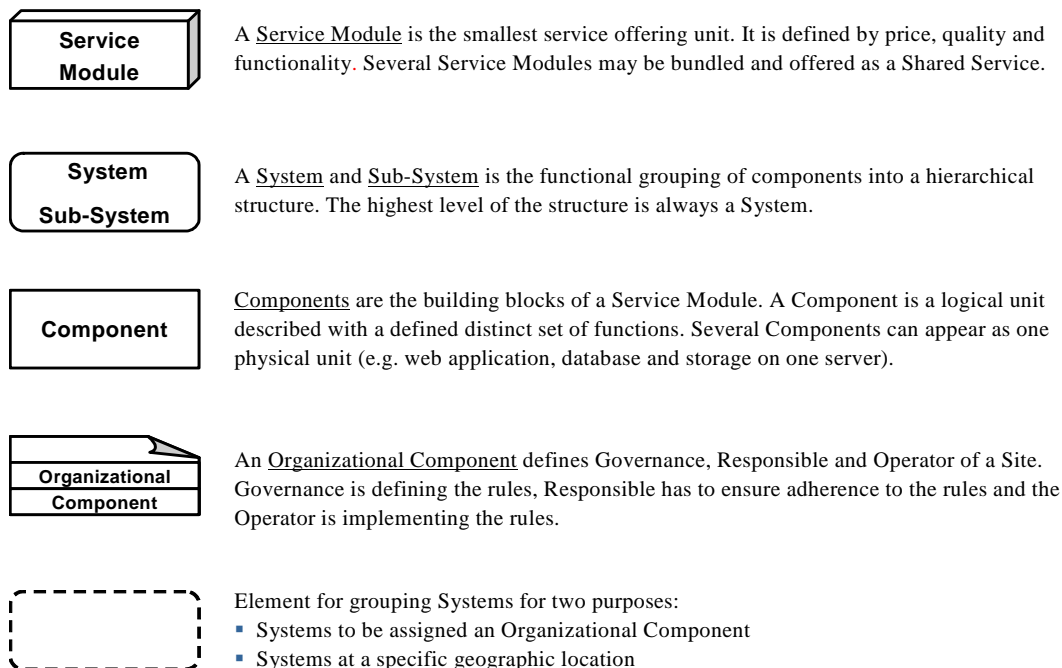

Figure 4: Notation for architecture views (extract)

The component view is used to convey the functional and logical structure of architecture. As depicted in the figure, the view is divided vertically into three major parts. One part is for client systems, one for server systems and one for storage systems (infrastructure building blocks). All service modules, systems, and components are described in terms of composition, structure and relationships among one another.

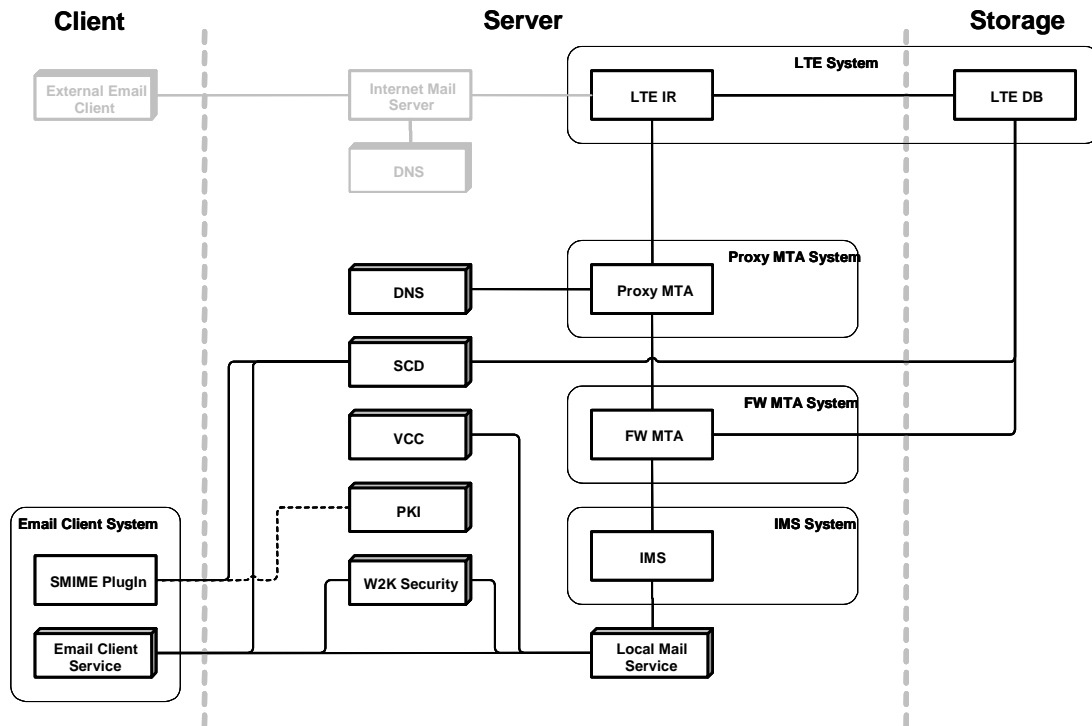

Figure 5: Component view (example Email Service)

The communication view describes the interaction between the service modules, systems, and components of the Email Service. The diagram is segmented in the communication areas Internet, Extranet, Intranet, Campus LAN, and Data Center LAN.

The distribution view describes the allocation of service modules, systems, or components in terms of geographical or organizational distribution. Like the component view, the distribution view is divided into three major parts. However, the distribution view is divided horizontally rather than vertically. The segmentation of the diagram follows the company’s organization in corporate, group, and region. In addition organizational responsibility is assigned which defines Governance, Responsible, and Operator of a Site. Governance is defining the rules, Responsible has to ensure adherence to the rules, and the Operator is implementing the rules.

The Email Service example illustrated the use of the three views for infrastructure architecture. The same principles for the design of the views are applied for applications architecture using the respective building blocks for the segmentation of diagrams. The views can be used at any level of detail for the decomposition of the chosen part of architecture (building block, service module, system). The combination of the architecture descriptions derived can be used for an integration of architecture in the large and in the small.

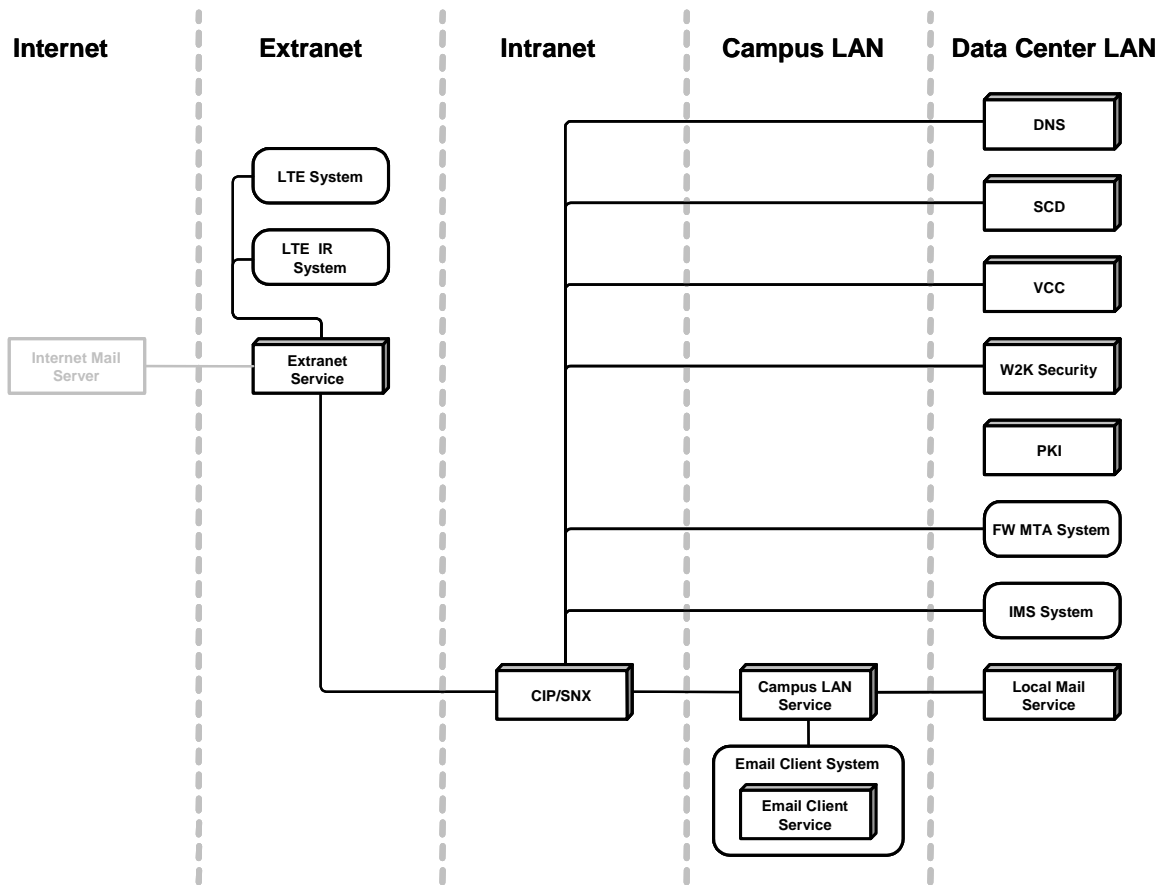

Figure 6: Communication view (example Email Service)

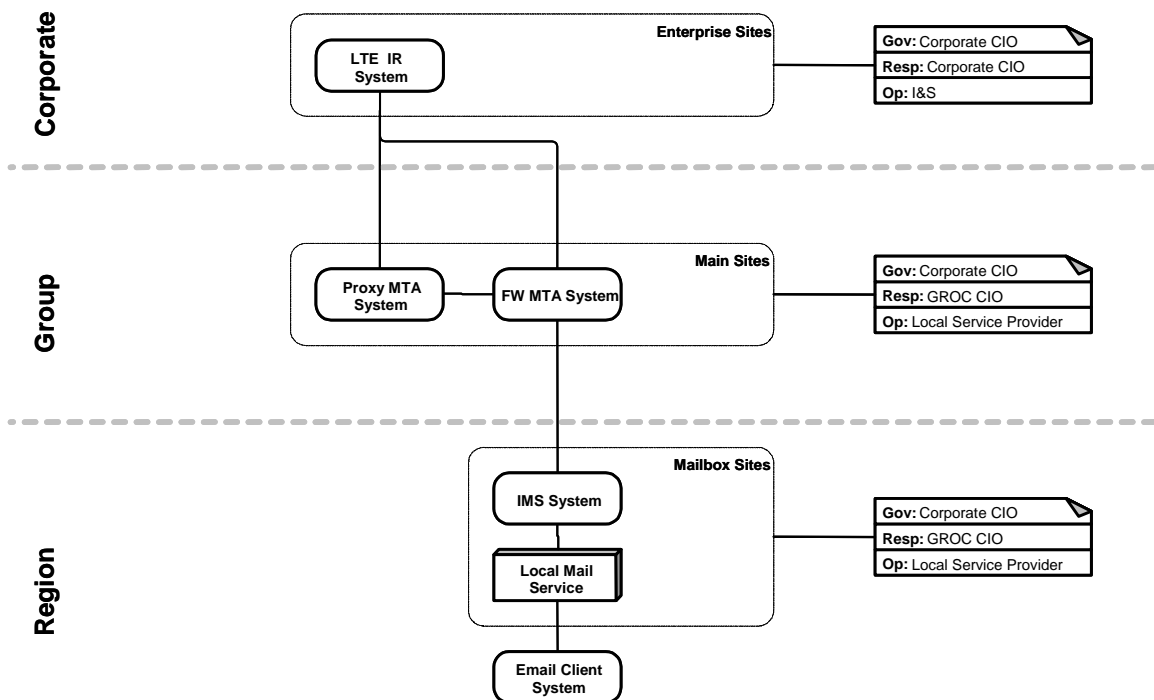

Figure 7: Distribution view (example Email Service)

4 BLUEPRINTS FOR ARCHITECTURE DEPLOYMENT

4.1 Dependencies of architecture building blocks

Enterprise Architecture is more than the collection of the constituent architectures. The inter-relationships among these architectures, and their joint properties, are essential to the enterprise architecture. Thus, the architecture domains should not be approached in isolation. Key element of architecture design is to account for interdependencies among the building blocks of architecture. Blueprints are introduced as a means in planning the deployment of architecture on a large scale. Blueprints give a comprehensive view on the building blocks and how they interact. They show the effects of architecture design between business, application, and infrastructure architecture.

In the focus of enterprise architectures is the alignment of business and IT. In other words, the design of the business architecture determines the IT Architecture which has to support and enable business. The building blocks of business architecture with the process architecture as the core define the frame for the design of the IT landscape. The dependencies between the different architectures can be described in blueprints. A blueprint is a plan which describes the deployment of an architecture building block across the enterprise. It pictures the landscape of this building block in a matrix of two business dimensions. The Figure 8 illustrates the derivation of main IT blueprints from the organization and process architecture.

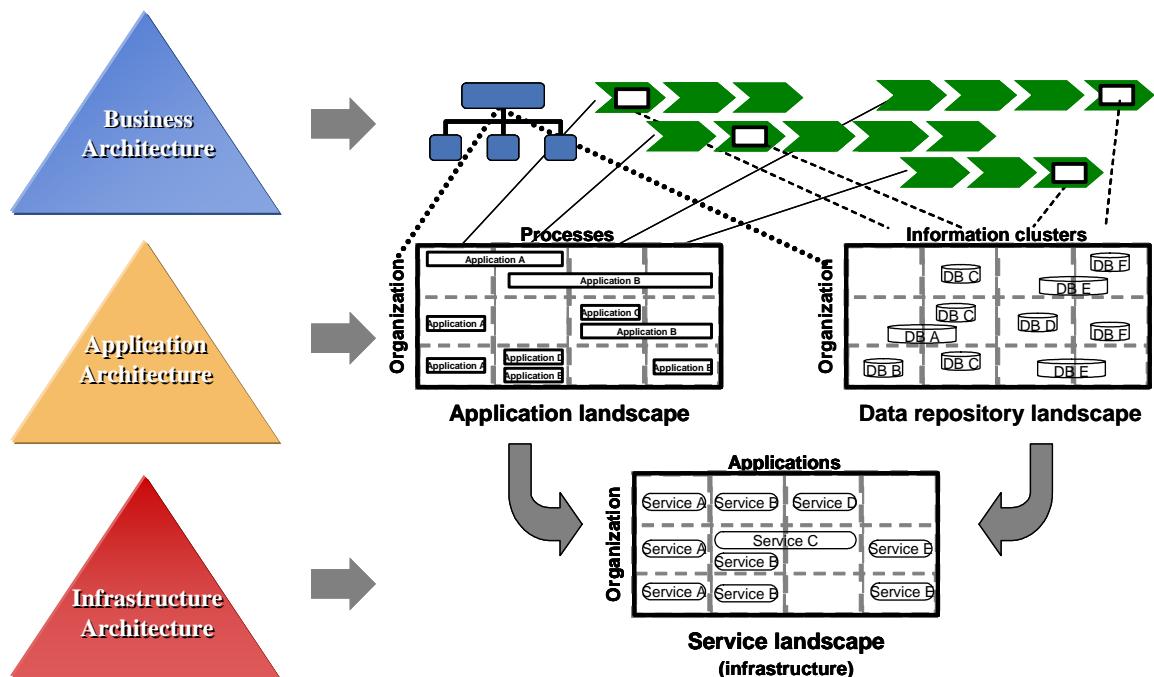

Figure 8: Main blueprints for IT architecture development

The application landscape describes for each business process how it is supported by applications. The second dimension shows the deployment in organizational units, like divisions, business segment etc.

The data repository landscape describes the deployment with databases and how the support defined information clusters of the information architecture. The second dimension shows the deployment of the databases in organizational units.

The service landscape shows the deployment of infrastructure services and the support of applications. The second dimension shows the deployment in organizational units.

In general, different types of blueprints can be generated depending which dependency of business -, applications -, and IT infrastructure architecture or building block is in focus. Also, the matrix dimensions can be chosen in different level of detail, although the experience in architecture projects shows that a high level is sufficient in order to derive decisions for architecture development. Generating to detailed blueprints involves a lot of resources and time without enriching the decision base in the same degree. The three blueprints introduced provide a good information base for management decisions. The following section gives an example of an application landscape for Siemens Medical being worked out in a corporate architecture project.

4.2 Blueprint for application landscape

Blueprints for application landscape are in the main focus in order to show IT support for business. The Figure 9 gives an example of an “as is” application landscape of the group medial solution of Siemens AG. The applications in use are mapped to level 1 business processes of the Siemens Reference Process House. Second dimension are the divisions of medical solution.

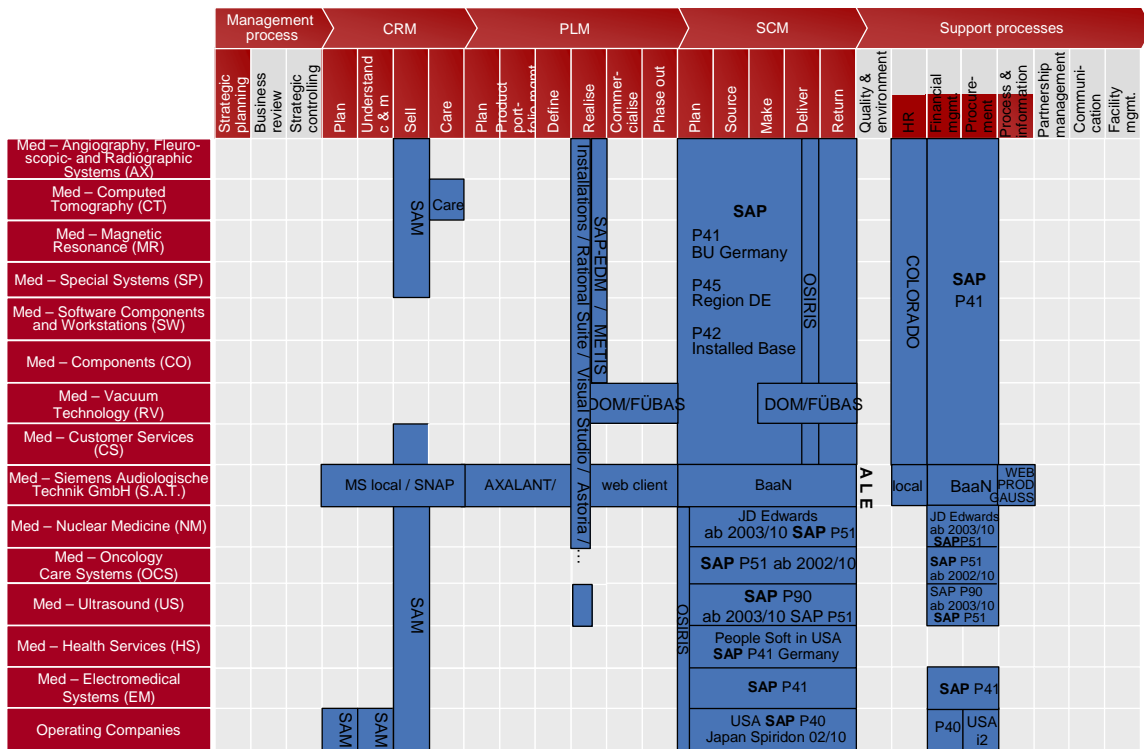

Figure 9. blueprint “as is” application landscape medical group Siemens AG

In a number of projects these types of blueprint have been proven to give a transparent overview on the application landscape and are a sound basis to derive architecture decisions. At a glance one can see processes not supported by applications or redundancies where more than one application is in place for a process. Blue prints are used for presentation of “as is” as well as target architecture. The blueprint of the target architecture describes the deployment plan to implement IT strategy. From the gap analysis of “as is” and target architecture IT projects are derived. Finally, the projects are prioritized and the overall IT program is defined in order to implement the architecture.

In order to generate different views of architecture all architecture documentation is stored in a repository. The Corporate modeler (Casewise 2004) is used and enhanced with additional features for architecture description. The IT Navigator (Siemens AG CIO 2002) was developed for analysis and assessment of architecture (blueprints, IT project portfolios etc.).

5 SUMMARY AND OUTLOOK

This paper introduced a comprehensive architecture framework, structuring the main building blocks of architecture. It can be used as reference for the constituents of enterprise architecture development. Based on the three basic views on architecture, complexity can be reduced and elementary construction principles of the architecture can be highlighted.

The component view shows the elements of architecture and their relationships, the communication view how the elements interact with one another. The distribution view describes how the elements are distributed in terms of location or organizational assignment. Furthermore blueprints give a comprehensive view on the building blocks and how they interact. They show the effects of architecture design between business -, application -, and infrastructure architecture.

The three architecture views support the reduction to core entities and construction principles of architecture. The blueprints for architecture deployment show the interdependencies between the building blocks and are designed for “architectures in the large”.

However, architecture development is very much management and communication among the different parties involved and not only technical construction. The techniques introduced are embedded in a well defined architecture development process. Architecture management and process are fundamental for a business oriented, sustainable development of enterprise architecture. Project experiences in this area will be addressed in a separate paper.

References

- AMICE (1994). (Esprit Consortium): CIM-OSA: Open Systems Architecture for CIM, Research Reports Esprit P. 688/5288, Berlin 1994
- Aranow, E. (2002). Enterprise Integration Strategies, Cutter Consortium 2002
- Bachmann, F. Software Architecture Documentation in Practice: Documenting Architectural Layers, Special Report CMU/SEI-2000-SR-004, March 2000
- Becker, J./ Schütte R. (2004):
Handelsinformationssysteme: Domainenorientierte Einführung in die Wirtschaftsinformatik, Frankfurt am Main 2004
- Birkhölzer, T./ Vaupel, J. (2003):
IT-Architekturen: Planung, Integration, Wartung, Berlin u.a. 2003
- Buschmann, F.; Meunier, R.; Rohnert, H.; Sommerlad, P.; Stal, M
Pattern-Oriented Software Architecture, A System of Patterns. John Wiley & Sons Ltd, Chichester, 1996
- Buhl, U.; Heinrich, B. (Ed.) (2004): Meinung/Dialog: Unternehmensarchitekturen in der Praxis – Architekturdesign vs. situationsbedingte Realisierung von Informationssystemen, Wirtschaftsinformatik 46(2004)4, p. 311-321
- Casewise (2004). Corporate Modeler, see <http://www.casewise.com/>, called 2004-10-30
- Clements, P.; Bachmann, F.; Bass, L. (2003). Documenting Software Architectures: Views and Beyond, Addison-Wesley, 2003.
- Encyclopaedia Britannica (Hrsg.) (1978): The new Encyclopaedia Britannica, Macropaedia, Vol. 1 “Architecture”, Chicago 1978, S. 1088 - 1115,
Encyclopaedia Britannica online:
<http://www.britannica.com/eb/article?tocId=9110410&query=architecture&ct=>

- Foegen, M.; Battenfeld, J. (2001). Die Rolle der Architektur in der Anwendungsentwicklung, Informatik Spektrum 24(2001)5; p. 290-301
- Günzel, H./ Rohloff, M. (2003):
 Architektur im Großen: Gegenstand und Handlungsfelder, in: Dittrich K.; König, W.; Oberweis, A., Rannenberg, K.; Wahlster, W. (Hrsg.): Informatik 2003 Innovative Informatikanwendungen, Band 2, Beiträge der 33. Jahrestagung der Gesellschaft für Informatik e.V. (GI) in Frankfurt a. M., Bonn 2003, Workshop „Enterprise Architecture – Architecture in the Large“, S. 422-425
- IEEE (2000), IEEE Standard 1471-2000, Recommended Practice for Architectural Description of Software-Intensive Systems. IEEE Computer Society, New York, October 2000
- Dern, G. (2003), Management von IT-Architekturen, Wiesbaden 2003
- Gartner Group (2002), Enterprise Architecture and IT “City Planning”, July 2002
- Krcmar, H. (2005):
 Informationsmanagement, Berlin et al. 2005
- Krcmar, H. (1990). Bedeutung und Ziele von Informationssystem-Architekturen. Wirtschaftsinformatik 32(1990)5, p. 395-402.
- Lapkin, A. (2004a): Architecture Frameworks: How to Choose, Gartner Research, November 2004
- Lapkin, A. (2004b): Architecture Frameworks: Some Options, Gartner Research, November 2004
- Martin, J./ Leben (1989). Information Engineering: Book I: Introduction, Englewoods Cliffs 1989
- Masak, D. (2005):
 Moderne Enterprise Architekturen, Berlin et al. 2005
- Matthes, F.; Wittenburg, A. (2004), Softwarekarten zur Visualisierung von Anwendungslandschaften und ihren Aspekten – Eine Bestandsaufnahme, Technischer Bericht München März 2004
- Meta Group (2002). Enterprise Architecture Desk Reference, 2002
- Österle, H. (1995). Business Engineering: Prozess- und Systementwicklung, Bd. 1:
 Entwurfstechniken, Prozess- und Systementwicklung, Berlin 1995
- Scheer, A.-W (1999). Architecture of Integrated Information Systems: Business Process Framework, Berlin 1999
- Siemens AG CIO (2002), IT-Navigator Tool Description, 2002.
- Siemens RPH (2004), Reference Process House, Version 2.2. , Siemens Process World:
http://vies1fba.wv300.siemens.net/WEB_RPH_Release/de/pages/index.htm, called 2004-10-30
- Sinz, E. (1997). Architektur von Informationssystemen, München 1997
- Sinz, E.J. (2002), Architektur von Informationssystemen, in: Rechenberg, P.; Pomberger, G.:
 Informatik Handbuch, München 2002, p. 1055-1068
- Sowa, J.F./ Zachman, J. (1992). Extending and Formalizing the Framework for Information Systems Architecture, in: IBM Systems Journal 31(1992)3
- TOGAF (2003), The Open Group Architecture Framework: Version 8.1 "Enterprise Edition",
 December 2003
- Zachman, J. (1987). A Framework for Information Systems Architecture, in: IBM Systems Journal 26(1987)3
- Zachmann Framework, see <http://www.zifa.com/> ,called 2004-10-30