

VALUE-BASED BUSINESS MODELLING FOR NETWORK ORGANIZATIONS: LESSONS LEARNED FROM THE ELECTRICITY SECTOR

Kartseva, Vera, Free University Amsterdam, Department of Economics and Business Administration, Information Systems Group, De Boelelaan 1105, 1081 HV Amsterdam, The Netherlands, vkartseva@feweb.vu.nl

Gordijn, Jaap, Free University Amsterdam, Department of Computer Science, De Boelelaan 1105 1081 HV Amsterdam, The Netherlands, gordijn@cs.vu.nl

Tan, Yao-Hua, Free University Amsterdam, Department of Economics and Business Administration, Information Systems Group, De Boelelaan 1105, 1081 HV Amsterdam, The Netherlands, ytan@feweb.vu.nl

Abstract

Speed and availability of information, delivered in past years by Internet technologies, made it easier for any company to outsource primary activities, which resulted in unbundling of many companies' traditional value constellations into networks of different companies. In the electricity power sector decomposition of the value constellation is not only enabled by technological advances such as small-scale electricity generation devices and Internet-based interconnections, but it is also enforced by government regulations and crucial ecological issues like CO₂ reduction.

In this paper we present a business modeling methodology, called e^3 value, which can be used to develop and reconstruct such value constellation in network organizations. This methodology combines rigorous conceptual modeling from Computer Sciences with the analysis methods from Business Sciences.

We show how the e^3 value methodology can be used in the field of distributed power generation. Four European electricity power companies are developing new business cases and the corresponding value constellations, of which we discuss one prototypical business example. For this case we present a e^3 value business model, and show how we can use this model to make a first financial assessment of the case. Finally, we discuss lessons learned from the e^3 value modeling in this specific business case of the electricity industry.

Keywords: value chain unbundling, business modeling, value model, e^3 -value methodology

1 INTRODUCTION

In many industries, networked business models are continuously subject to change. Consider for instance the electricity power industry. Due to societal considerations (reduction of CO₂ emission, increase of efficiency) as well as technological innovations (interconnected ubiquitous computing, multi agents systems) the international electricity power industry changes, and new constellations with innovative value offerings emerge. Policy makers need to check whether the current regulation do not prevent the development of new businesses, and what are the promising business models that require the policy support. In this paper we demonstrate how business modeling methodology *e³-value* was applied to discover, conceptualise and evaluate new business models in the electricity sector with the further goal to provide directions for policy.

This study is relevant for various reasons. For the electricity sector, this research shows the applicability of tools delivered by e-business modelling research (Alt and Zimmerman (2001), Osterwalder and Pigneur (2002), Pateli and Giaglis (2002), Petrovic et al. (2001), Tapscot et al. 2000), in particular *e³-value* modelling (Gordijn and Akkermans 2003). The *e³-value* methodology achieves these goals by utilising conceptual graphical modelling (Wiegiers 1999), and scenario-based thinking, which is often applied in strategic analysis (Van der Heijden 1996). In this paper we further develop the *e³-value* methodology, apply it to a new domain, namely to the electricity sector, and present lessons learned. From the e-business modelling point of view, the domain of the electricity sector gives an alternative perspective on the area of network modelling, and it provides a new view on problems and opportunities of business modelling. In addition, this study shows the relevance of business-modelling techniques in a domain where typically only conventional financial and strategic analysis tools are applied.

2 THE ELECTRICITY SECTOR

2.1 Trends in the electricity sector

Currently, the electricity power industry is in a disruptive transition: the market changes from a few monopolistic supply-side players per country to thousands of supply side enterprises and customers with possibility to select their electricity provider. Supply side players comprise generators of electricity, distribution companies, suppliers, price formation entities such as exchanges and more.

From a *societal perspective*, two issues are of importance to understand the ongoing transition: (1) increase of industry efficiency, and (2) reduction of environmental impact, caused by electricity generation and consumption. Both issues lead to *re-regulation* of the electricity sector. Concerning industry efficiency, the aim is to produce and distribute electricity at lower costs than before. In many countries there is ample opportunity for efficiency improvement. To explain this, consider the following equation that should always hold in the case of the electricity industry:

$$\text{For each moment in time: } \text{Electricity}_{\text{consumed}} < \text{Electricity}_{\text{produced}} \quad (\text{Power equation})$$

The formula states that the total amount of produced electricity should *always* be larger than the total amount of consumed electricity. This seems a simple equation, but the reader should realize that if, at some point in time, the amount of produced electricity drops below the amount of consumed electricity, power outages for an entire region occur as we have seen in some countries recently. To guarantee that this equation holds, there is always over-capacity in electricity generation, sometimes even 150% of consumed electricity. Increasing industry efficiency is about reducing this over-capacity to 105-110%. As we will see later, IT innovations play an essential role in this efficiency increase. Environmental impact reduction is mainly about reduction of CO₂ emission, typically caused by fossil

fuels. There are a number of ways to reduce CO₂ emission: for instance a decrease in overall electricity consumption, or the use of electricity generation techniques that do not use fossil fuels, but rather employ sun, wind, hydro, geo-term, or tide energy. These are collectively called *renewable* energy sources.

Both the increase of industry efficiency and the reduction of environmental impact leads to re-regulation: many electricity parties, formerly being state-owned enterprises, are now transformed into market driven companies, but are governed by rules to guarantee reliability of electricity production in a market-driven environment. In addition, the use of renewable energy requires re-regulation because currently renewable energy is much more expensive than energy generated with fossil fuels, so some subsidy scheme (that is: regulation) should be in place.

Market transition in the electricity sector is also driven by new *enabling technologies*. In short, technology enables *Distributed Generation* (DG) of electricity by many generators. With respect to technological innovation, we distinguish (1) electricity generation technology and (2) Internet and Information technology. Currently, there are techniques to generate electricity on a *small scale*, which are *sometimes* renewable. For instance, PV-solar cells, hydro power, and wind-mills are renewable energy technologies that can be employed on a small scale (typically < 50 MW). An example of a small scale but not-renewable generation technique is Combined Heat Power (CHP) production: a gas-fuelled heating device (e.g. in your basement) that as a side product also generates electricity power. Both these small scale generation techniques lead to an enormous growth of the number (tens of thousands!) of electricity producers, whereas in former days there were only a few large producers per country.

This huge amount of generators leads to an immense control problem. How can the power equation be guaranteed with so many generators? A prerequisite is that it must be possible to switch on in a few seconds additional electricity power if required, especially if over-capacity will be decreased in the order of magnitude of 105-110%. Coordinating the availability of sufficient power in the situation of a few generators is relatively straightforward. If more power is needed, a control authority selects one of the few suppliers and asks to deliver more power, sometimes by phone. But how should this be accomplished in the new situation, characterized by thousands of generators? First, there should be some control mechanism in place that is able to switch on/off generators based on the electricity power consumption forecast within seconds. In addition, there is a need for price-formation. In the old situation, price formation was done with a few parties, now thousands of parties participate in this process.

Information technology is essential for the required control mechanisms to manage thousands of generators and consumers. First, the need to exchange real-time information in the network organization consisting of on the one hand numerous energy generators, and on the other hand energy consumers would be impossible without the Internet that offers a cheap, widely available, and efficient communication channel between generators, consumers, intermediate parties, and regulation authorities. Via the Internet, parties for instance communicate requests for additional electricity power within seconds. Additionally, artificial agent technologies provide facilities for controlling electricity generators and consumers in a distributed fashion, and offer facilities for pricing and negotiating (Ygge 1999). "*Distributed*" means that every device (PV-cell, wind-mill, heating, fridge, etc.) can have its own software agent (which sometimes communicates via a GSM chip!) to control and forecast electricity production and consumption. In some cases these agents negotiate prices among each other via sophisticated online auctions such as spot markets, stock and option markets and other forms of advanced auctioning. In sum, information technology such as Internet technology and agent technology are a critical enabler for the formation of these high-tech network organizations that create distributed generation and consumption of electricity in the modern electricity industry.

In conclusion, both these societal and technological developments lead to an electricity industry that is transformed from the industry that is dominated by a few electricity companies (mostly monopolistic and state-owned) to many (thousands) privately owned electricity companies. In addition, this

transition results in new enterprises too, for instance companies offering services to keep the electricity power equation at all times (so called balancing services), companies handling pricing information, and more. As a result, new services are developed, new partnerships between enterprises emerge and revenue streams change (e.g. as a result of subsidy schemes). Basically, the electricity industries have to re-invent their value propositions. We capture such a proposition by means of a *conceptual value model*.

2.2 Conceptualizing the electricity sector

It is important to understand the notion of conceptual modelling well in order to see the merits of the e^3 -value methodology. *Conceptual modelling* stems from Computer Science and comprises the activity of formally defining aspects of the physical and social world around us for the purpose of understanding and communication (Mylopoulos 1992). *Formal* in this context means the abstraction, structuring, and representation of knowledge in a way that makes it possible to reason about this knowledge (Loucopoulos and Karakostas 1995). The e^3 -value methodology uses conceptual modelling as a *methodology* to elicit, describe and analyze a value proposition. Additionally, in doing so we use well-known terminology from Business Administration and Organizational Sciences.

The activity of conceptual modelling is well-known and accepted in the information technology community, but business-oriented stakeholders are often unaware of this approach. These stakeholders typically use natural language to represent and communicate their requirements. There are a number of drawbacks with such natural language representations, such as noise (irrelevant information), silence (omission of important information), over-specification, contradictions, ambiguity, forward references, and even wishful thinking (Meyer 1985).

- In network business models, stakeholders often have different view on value propositions and different interests, which, when communicated in natural language, lead to incomplete, ambiguous, multi-interpretable statements. The process of design of network organisations, including developing new propositions, is performed unstructured and is therefore time-consuming. Additionally, many networked value propositions, enabled by new yet hardly understood technology are not profitable (see the recent e-commerce past, see Shama 2001). The e^3 -value methodology is a conceptual modelling approach for capturing networked value constellations and tackles these problems by precisely defining *limited* library of concepts and utilising strategic, scenario based, decision making techniques (Van der Heijden 1996) to describe value propositions. These concepts are based on well-known work on the network economy such as (Holbrook 1999, Porter 1980&2000, Tapscott 2000). The conceptualization makes conflicts explicit, thereby helping stakeholders to resolve these conflicts in an early stage of development.

3 THE E^3 -VALUE METHODOLOGY

The e^3 -value methodology (Gordijn & Akkermans 2003) allows conceptualising a business case by constructing a value model, representing it graphically in a rigorous and structured way, and performing a financial sensitivity analysis of the case at hand. In particular, the e^3 -value methodology provides modelling concepts for showing which parties exchange things of *economic* value with whom, *and* expect *what* in return. The methodology has been previously applied in a series of industries including media, banking & insurance, and telecommunication (Gordijn and Akkermans 2003) to design value models of network organizations. Especially, cases in the telecommunication industry show similarities with the electricity sector with respect to re-regulation.

The *value* modelling concepts are expressed as an *ontology*, which is "... an explicit specification of a conceptualization" (Gruber 1994). Modern definitions of ontology (see e.g. Borst et al. 1997) emphasize that there must be an *agreement* on the conceptualization that is specified. This notion of

shared conceptualization is important to us, because we aim at a common understanding of networked businesses and their propositions by stakeholders involved. To contribute to a common understanding, we base our ontology on well-known concepts from business administration and organizational sciences.

To be useful for conceptual modelling in practice, an ontology should contain only a limited number of concepts. Stakeholders have to understand these concepts because they should express conceptual value models using these concepts, and we have observed that it is virtually impossible to do this with a large number of concepts. A number of business driven ontologies exist (Usschold et al 1998, Fox and Gruninger 1998, Geerts and McCarthy 1999) but they all contain too many constructs to be useful for conceptual modelling in practice. As an example consider Malone et al (1999). They provide ontology constructs for “inventing organizations”. They propose an ontology with about 3400 different activities with 20 levels of specializations and 10 levels of decomposition. Such a complex ontology is hardly suitable for exploring new networked propositions. A reason for this complexity is that Malone’s ontology (and many others) focuses on a *business process* (the ‘how’) rather than on a networked *value proposition* (the ‘what’). In contrast, by focusing on the value proposition solely, the *e³-value* methodology provides a tractable number of ontology constructs and allows users to abstract away from the operationalisation by means of business processes.

We now shortly describe the concepts of the *e³-value* methodology using an educational example (see Figure 1)

Actor. An actor is perceived by its environment as an independent economic (and often also legal) entity. An actor makes a profit or increases its utility. In a sound, sustainable, business model *each* actor should be capable of making a profit. The example shows a number of actors: a *store*, a *wholesaler*, a *logistics provider*, and a *manufacturer*.

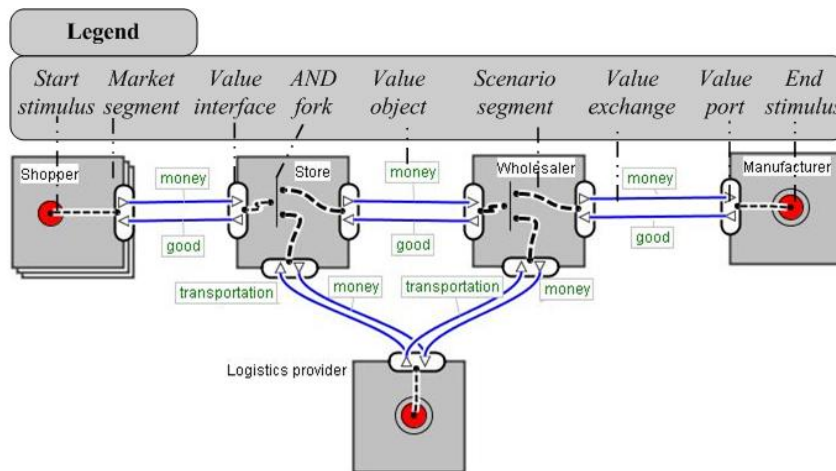

Figure 1 A shopper obtains a good from a store and offers money in return. So do the other actors. The scenario path shows that in reaction to a start stimulus (a consumer need), the store needs to buy a good also as well as transportation of the good, and so does the wholesaler.

Value Object. Actors exchange value objects, which are services, products, money, or even consumer experiences. The important point here is that a value object is *of value* for one or more actors. *Good* and *money* are examples of value objects, but *transportation* service is also a value object.

Value Port. An actor uses a value port to show to its environment that it wants to provide or request value objects. The concept of port enables us to abstract away from the internal business processes,

and to focus only on how external actors and other components of the business model can be ‘plugged in.

Value Offering. A value offering models what an actor offers to or requests from his/her environment. The closely related concept *value interface* (see below) models an offering to the actor’s environment *and* the reciprocal incoming offering, while the value offering models a set of equally directed value ports exchanging value ports. It is used to model e.g. bundling: the situation that some objects are only of value in combination for an actor.

Value Interface. Actors have one or more value interfaces, grouping individual value offerings. A value interface shows the value object an actor is willing to exchange *in return for* another value object via its ports. The exchange of value objects is atomic at the level of the value interface.

Value Exchange. A value exchange is used to connect two value ports with each other. It represents one or more *potential* trades of value objects between value ports.

Market segment. The concept *market segment* shows a set of actors that for one or more of their value interfaces, value objects equally from an economic perspective. *Shopper* is an example market segment. Here we assume that all (implicit) actors in the *shoppers* segment value obtained and delivered objects in the same way. Naturally, this is a simplification of the real world, but choosing the right simplifications is exactly what modelling is about.

The concepts above allow us to model who wants to do business with whom, but can not represent *all* value exchanges needed to satisfy a particular end-consumer need. It occurs often that, to satisfy an end consumer need, several other actors have to exchange objects of value with each other. As an example think of a store that exchanges economic values with an end consumer: as a result, the store must also exchange values with a wholesaler. It is our experience that showing all such value exchanges to satisfy an end consumer need contributes largely to a common understanding of an e-business idea. To that purpose we use an existing scenario technique called Use Case Maps (Buhr 1998), which show which value exchanges should occur as a result of a consumer need (which we call a start stimulus), or as a result of other value exchanges. Below, the main UCM modelling constructs are briefly discussed.

Scenario path. A scenario path consists of one or more scenario segments, related by connection elements and start and stop stimuli. A path indicates via *which* value interfaces objects of value must be exchanged, as a result of a start stimulus, *or* as result of exchanges via *other* value interfaces.

Stimulus. A scenario path starts with a **start stimulus**, which represents a consumer need (in the example the need for a specific good). The last segment(s) of a scenario path is connected to a **stop stimulus**. A stop stimulus indicates that the scenario path ends.

Scenario segment. A scenario path has one or more segments. Segments are used to relate value interfaces with each other (e.g. via connection elements) to show that an exchange on one value interface causes an exchange on another value interface.

Connection element. Connections are used to relate individual scenario segments. An **AND fork** splits a scenario path into two or more sub paths, while the **AND join** collapses sub paths into a single path. An **OR fork** models a continuation of the scenario path into one direction that is to be chosen from a number of alternatives. The **OR join** merges two or more paths into one path. Finally, a value interface itself is seen as a connection element, so it is for instance possible to connect two value interfaces by a scenario segment (as can be seen in Figure 1). The *AND fork* is exemplified in Figure 1. The figure says that in order to exchange goods and money with a shopper, a store needs to obtain the good itself (and provide money in return) *and* a store needs to obtain transportation (to deliver to good physically)

4 BUSMOD PROJECT: CONCEPTUAL MODEL & LESSONS LEARNED

For the present business case, we consider the following situation. A former big utility, split into a producer, a supplier, and a distribution system operator, has the objective to avoid the risk of doing nothing with renewable technologies, while the rivals do, and receive revenue from favourable subsidising schemes that are currently provided in Spain for some renewable technologies. This company is interested to invest into small-scale renewable generation to be installed on the distribution grid (Distributed Generation).

To finance the relatively high investments for renewable energy, Spain implemented a *subsidy system*, which can shortly be described as follows. First, the Spanish government subsidises electricity producers that comply with so-called “special rules” (further in the paper it will be referred to as “renewable producers”). Renewable producers are electricity generation plants of less than 50 MW capacities, which generate electricity using renewable energy sources or some other types of sources that deliver more efficient electricity with less environmental impact. The subsidy is paid according to the amount of the renewable electricity produced. The money for the subsidy comes from final customers: they pay an additional fee for the electricity consumed (regardless whether it concerns renewable or non-renewable electricity). Second, the supplier is obliged to give priority to the renewable producers, and to purchase all the energy they want to sell, before they can purchase the energy from regular producers. Third, there are tax exemption schemes for investments into some renewable technologies. As a result of these mechanisms, producers of renewable energy receive higher price plus favourable conditions, not to mention investment discounts. In the extreme case of generation with small-scale photovoltaic panels (sun) the producer was subsidised for about 360 Euro/MWh, while the average electricity market price was 35 Euro/MWh¹, i.e. the photovoltaics sell their electricity for the price more than 10 times higher than, for example, a thermal producer. These conditions make the business case interesting for the investigation from the point of view of sustainability.

4.1 A business model for distributed power generation

The business case described above is shown in the model in Figure 2. The model represents generation of electricity by a renewable generator, which is installed into the distribution grid. In practice this means that the generator is physically located nearby the consumers of the generator’s electricity. We follow the scenario path to explain the business model. The final customer is any legal or natural person buying electricity for its own use. The scenario starts when a final customer wants to purchase electricity. Supplier performs sale and procurement functions (electricity purchasing and selling): delivers electricity to the final customer and receives the electricity retail fee in return ((a)).

Following the scenario path, we can see that the path splits into several sub-paths. The leftmost sub-path (b) presents that energy must be obtained, either from a traditional producer (exploiting non-renewable energy) (c), or from a renewable producer (d). The second sub-path (g), shows that for *all* energy exchanged between customer and the supplier a *Renewable Energy Source* (RES) tax has to be paid to the *National Energy Committee* (NEC). NEC is a government institution in charge of a fund that is used to pay renewable producers a premium for generating such energy; a fund is a collection of all the RES taxes paid. If we assume that the supplier decides to obtain renewable energy, the scenario continues in the direction of annotation (d), and again splits into two sub-paths. The left sub-path (e) models that renewable energy is bought, and the renewable energy producer receives a fee and premium for the energy. The supplier obtains the premium fee to be paid from the NEC, as can be seen from the sub-path, annotated (f). Finally sub-path (g) and (i) show exchanges of the supplier with, correspondingly, the transmission system operator (operates the high-voltage, long transmission grid)

¹ Red Eléctrica de España (2001) Red Eléctrica de España, El Sistema Eléctrico Español Informe 2001, Spain, 2001 available in http://www.ree.es/index_sis.html

and distribution system operators (operates medium- and low-voltage distribution grid); the supplier pays a fee for the transmission and distribution services the operators deliver.

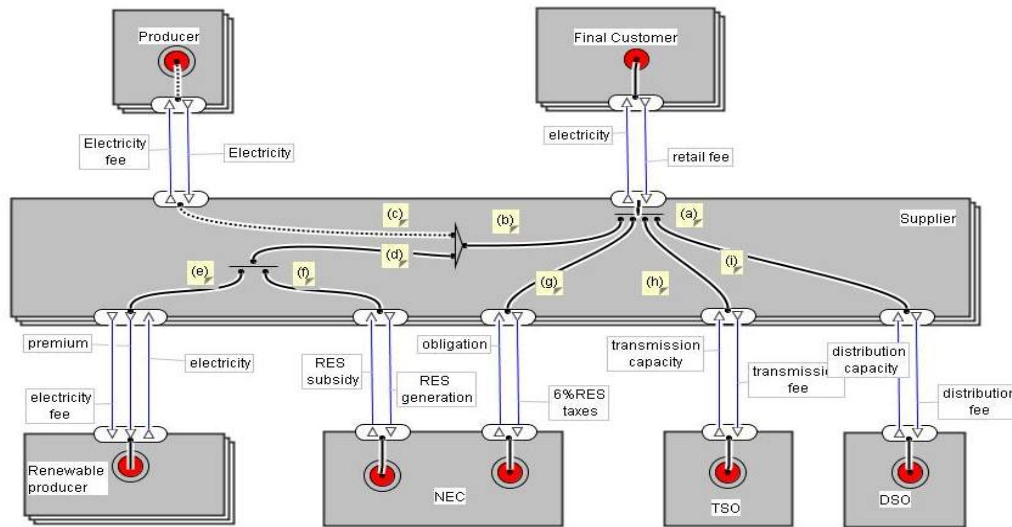

Figure 2 Conceptual model of the business scenario at the deregulated Spanish electricity market

4.2 Financial analysis

A next step will be to carry out a thorough profitability analysis in a quantitative way, which is also part of the e^3 -value methodology. Essentially, it is possible to generate for each actor involved the expected net cash flow, based on the consumer need (in this specific the amount of KWh electricity consumed). For brevity, we show in this section the conventional profitability analysis only concisely (see (Gordijn and Akkermans 2003) for a more detailed discussion).

To calculate profitability of each actor we (1) assign a formula to each value object exchanged, and (2) extract the total value of the outgoing objects from the total value of incoming objects. For example, for the *supplier* we can write down the following *profitability sheet*:

Exchanged with actor	Value In	Value Out
Final Customer	Elect. Retail fee 97.370.041	(Electricity)
TSO	(Transmission capacity)	Transmission fee 2.947.299
DSO	(Distribution capacity)	Distribution fee 24.124.192
NEC	(Legal Obligation)	Total RES taxes 6.549.554
<i>Conventional path</i>		
Producer	(Electricity)	Electricity fee 35.172.630
<i>Renewable path</i>		
NEC	RES subsidy 22.697.552	(RES generation)
RES producer	(Electricity)	RES premium 22.697.552
		Electricity fee 15.040.620

Table 1. Profitability sheet for supplier

In these specific calculations we take a look at the Bask Autonomous region, and consider the generation facilities and data in this region only. In 2001 in this region renewable producers produced 2 259 GWh electricity, and non-renewable - 966 GWh. The electricity paid to the generator is priced according to the electricity tariff: 15.57€/MWh - 46% of the total electricity price paid by customer; the rest is RES tax (16.50%), of which 6% goes to pay premiums for RES producers, and the rest 10,5% is for paying electricity fee for RES producers, transmission fee (2.7%), distribution fee (22.1%), commercialising fee charged by supplier (1.9%), and other taxes and fees² (10.8%). The price of electricity taken is 30.19 €/MWh (we did not include “other taxes and fees” in calculations). The operation and maintenance expenses are not taken into account for any actor, so the numbers in Table 1 are gross profits. In the profitability sheet for suppliers every number was calculated through the formula assigned to the value object. Like, for example, electricity retail fee paid by all final customers in the region is a product of electricity retail price (30.19 Euro/MWh) and total annual electricity consumption from the plants in the region (3 225 MWh). The result of profitability numbers for each actor is shown in Table 2.

Producer	RES producer	NEC	Supplier	Customer ³	DSO	TSO
35.172.630	37.738.172	-16.147.998	13.535.746	0,00	24.124.191,85	2.947.299

Table 2. Gross profitability for each actor

NEC, the government organization in charge of managing the premium system, has a negative profitability. The incoming value objects for the NEC are RES taxes, and outgoing objects are subsidies. Having in mind that in this financials we took into account only data for Bask Autonomous community, the negative total profitability of the NEC means that there is more money paid for subsidies in this region than taxes collected from customers in this region. In fact, we see that in the region there is another source of money to be paid for subsidies coming probably from other regions, or from other taxes.

At first sight, the profitability of the RES producers is positive. But if we look specifically at some *types* of renewable producers and take into account operational and maintenance expenses, we estimated that hydropower and wind power have a positive net cash flow, while, for example, refined gas plants resulted with negative cash flows (550 388 loss), which means that their expenses are not covered.

The negative cash flows of some actors (in this case the NEC actor) in the financial analysis in the previous section are the evidence that the business model does not bring profit to every actor involved, and therefore, it can not be considered sustainable. In other cases, it can happen that the formulas or numbers were incorrect. The negative profitability is an incentive to ask yourself these questions, and to discover that the model you build is either incorrect or unprofitable. For this business case, NEC spends more money on subsidies than is obtained from suppliers and finally end-customers. The outcome of this analysis led to changes in the subsidy scheme.

4.3 Lessons learned

During the BUSMOD project (an EC-EESD funded project, see <http://busmod.e3value.com>) we had an opportunity to present the *e³-value* methodology to project partners from Spain, Norway, UK, and the Netherlands and to use it to develop business models of present and future scenarios of their markets. The project meetings were held several times a year. As in the presented Spanish case, other

² Other taxes and fees include: contract between REE and EdF (1,1%); costs of extra-peninsular systems of Spanish islands and enclaves in Morocco (1,5%); the Market Operator costs (0,1%), the System Operator costs (0,1%); costs of the National Energy Commission (0,1%); stranded costs (3,6%); paid to non-feasible power plants to keep them in the system in order to guarantee the supply; nuclear moratorium (3,5%); paid to recover the investments of prohibited nuclear plants; nuclear fuel treatment costs (0,8%)

³ The market value of electricity for the final customer is taken equal to its value according to the tariff

partners were also asked to build models as well as give textual descriptions of their business cases. In total we investigated 12 different scenarios of four different countries, developed by at least by four different modellers. There were two meetings hold where partners presented their business models: in the beginning of the project, before explaining the e^3 -value methodology, and several months later, after explaining the methodology. The methodology was explained at a one-day workshop, and also partners were provided with a rigorous manual. Additionally, we consulted partners on the development of business cases on a regular basis by email or phone. Several lessons were learnt about the performance of e^3 -value methodology. In sum, the e^3 -value methodology provides similar terminology and focus of the business models, which results in the improvement of the overall quality of the analysis, as well as better learning environment.

Lesson 1: The e^3 -value methodology creates an efficient learning environment. Creating efficient learning environment is essential for efficient decision making in the groups of international, multiple background participants. e^3 -value methodology can play a role of a communication tool to share ideas about different design decisions in markets, policies and value constelations. During the creation of the value module presented in Figure 2 the modeller made different design decisions, for example:

- **Actors and market segments.** The design decision was made to address the features of the deregulated market: the supply and generation are shown as market segments, and the monopolistic distribution, transmission, and government institution are shown as single actors. Before the deregulation, the supply and generation would also be shown as single actors, or even as one actor in the case of the utility. These single actors imply a *monopolistic* situation: end-consumers could only obtain the electricity from one single enterprise. In the new situation, suppliers are a market segment, denoting that end-consumers can choose from a number of electricity suppliers.
- **Value objects.** The design decision was made to introduce various value objects that represent the policy implemented. For example, the premium value object represents the subsidy paid to the renewable producers. This highlights the various policies, which are valuable for the government (e.g. compliance with Kyoto agreements) or the society, and models their the influence on business propositions.
- **Scenario path.** The design decision was made to show the OR-fork that splits into renewable generation path (d) and conventional generation path (Figure 2, c), which is shown with dotted line. This design decision was made by policy makers to provide priority for renewable producers. However, one more design decision was made to make the sub-path (g) independent of the OR fork. This design decision states that for final customers there is no difference which electricity is delivered to them: renewable or not, they pay the same price. Due to such a policy design, *all* the energy funds renewable energy, and one can even suggest that with this premium system new renewable energy sources are sponsored only if there are enough traditional sources to support them.

During meetings, the e^3 -value modelling concepts provided a comprehensive framework for discussions about business cases. Before using e^3 -value, when asked to explain the business scenario, the partners used different terms and different levels of analysis of business case: some concentrated on technology, others on policy. This led to all kinds of different questions and comments that resulted in a more than one-hour discussion about a single scenario. Using the e^3 -value graphical representation to present the scenario, the discussions of different models acquired a single focus on economic value proposition and design decisions in policies and markets. People in the group talked in terms of e^3 -value concepts, and had a clear graphical picture that everyone in the room understood. As a result, they were able to reduce the timeslot for presenting a model to 20 minutes. Additionally, using e^3 -value as a framework resulted in the better quality of textual descriptions of business cases in terms of similar terminology and focus.

Lesson 2: The e^3 -value methodology contributes to a better understanding of the business case. Originally the textual description of the business case written by the Spanish partners consisted of more than two A4 pages, and basically, was incorrect. Only after e^3 -value modelling the details of the system became clear, even for the domain experts themselves. It took us more than three sessions of

verification with domain experts to develop the correct business model. The final feedback led to important improvements of the business case model. For instance, the domain experts realised that a different actor was responsible for the premium system management, and that the pricing system was different than they initially thought. In sum, these sessions of business modelling helped domain experts to achieve a better understanding of their own business case.

Lesson 3: The e^3 value methodology allows the comparison and re-use of business models. The comparison of natural language description of business models makes it difficult to reuse. The textual descriptions of the business scenarios had in common that they had different focus, which made the comparison between various business models very hard. One of the overall BUSMOD project goals was to develop business models common for the European market. To do that it is necessary to be able to compare models, and to reuse a model developed for one country for another country. Having a business case, described with e^3 -value, the comparison and reuse can be done much simpler, because all models are represented within one focus and use similar terms.

Lesson 4: The e^3 value methodology is an intuitive approach. The scenario-based thinking used in the e^3 -value methodology is useful because of the intuitiveness of the approach. Basically, it was not necessary to explain the partners what a scenario is, rather it was intuitively clear for them. Furthermore, the ability to annotate the conceptual model with financial data and to “execute” the model (and generate profitability sheets) was positively evaluated by the partners. What is needed to enhance the usability of methodology is software support for e^3 -value. In the IST-EC funded project OBELIX (see <http://obelix.e3value.com>) a support tool is currently developed. A prototype version of this tool can be obtained from <http://www.cs.vu.nl/~gordijn>

Lesson 5: The e^3 value methodology provides handles for designing control mechanisms. The electricity sector involves a great deal of regulation. Regulation always requires control mechanisms that optimizes the likelihood that actors will comply with the regulation. Although control mechanisms cannot be represented straightforwardly in the current version of the e^3 -value methodology, it does provide a structured basis for modelling the requirements analysis of controls. For example, for a scenario path to be executed, several conditions have to be fulfilled. First of all, economic reciprocity has to be preserved; e.g. in the value model in Figure 2 the electricity can be delivered from the renewable producer *only* if both electricity and premium are paid back (this is the semantic of the value interface: either all ports in an value interface exchange value objects, or none at all). In addition, controls are often needed for value objects, as these objects sometimes represent regulation. For instance, the obligation object exchanged between NEC and the supplier represents that a supplier fulfils his obligation to pay a tax for all electricity sold. In sum, the e^3 -value methodology provides an excellent framework for the development of other methodologies, namely a methodology for modelling control mechanisms. The control issues were already addressed by (Gordijn and Tan 2003), but further research is needed.

5 CONCLUSIONS

In this paper we presented an economic value-based modelling technique called e^3 value. We have used this technique in a complex multi-actor network to design various business models for distributed generation of electricity power. This industry undergoes a substantial transformation, both as a result of de-regulation and technological advances. We have discussed experiences with using the e^3 value methodology in a real-life project. It was shown that the e^3 value business modelling is able to create a better learning environment, and achieves a better understanding of the business case. In addition, e^3 value utilises familiar scenario based financial modelling approach that makes it more usable. Finally, a well-structured methodology, such as e^3 value, enables comparison and reuse of business models, and provides a strong framework for the development of regulations and control mechanisms. We observed all above mentioned effects of e^3 value business modelling during the international research project BUSMOD. One of the business cases developed during this project was demonstrated in this paper.

Acknowledgements. This research was partly funded by the EC-EESD project BusMod and by the EC-IST project OBELIX.

References

- Alt, R. and Zimmerman H.D. (2001). Preface: Introduction to Special Section – Business Models. *Electronic Markets*, 11 (1), 3-9.
- Borst, W. N., J. M. Akkermans and J. L. Top. (1997). Engineering Ontologies. *International Journal of Human-Computer Studies*, 46, 365—406.
- Buhr, R. J. A. (1998). Use Case Maps as Architectural Entities for Complex Systems, *IEEE Transactions on Software Engineering*, 24 (12), 1131—1155.
- Fox, M.S. and Gruninger, M. (1998). Enterprise modelling. *AI Magazine*, Fall, 19(3), 109-121.
- Geerts, G. and McCarthy, W.E. (1999). An Accounting Object Infrastructure for Knowledge-Based Enterprise Models. *IEEE Intelligent Systems and Their Applications*, July-August, 89—94.
- Gordijn, J. and Akkermans, J.M. (2003). Value based requirements engineering: Exploring innovative e-commerce idea. *Requirements Engineering Journal*, 8(2), 114-134, see also <http://www.cs.vu.nl/~gordijn/>.
- Gordijn, J., and Tan, Y. (2003). A Design Methodology for Trust and Value Exchanges in Business Models. *Proceedings of 16th Bled conference*, Bled, Slovenia, 423-432.
- Gruber, T.R. (1994). Towards Principles for the Design of Ontologies Used for Knowledge Sharing. In: *Formal Ontology in Conceptual Analysis and Knowledge Representation*. N. Guarino and R. Poli (eds.). Kluwer, Amsterdam, NL.
- Heijden van der, K. (1996). *Scenarios: The Arts of Strategic Conversation*. John Wiley & Sons Inc., New York, NY.
- Holbrook, M.B. (1999). *Consumer Value: A Framework for Analysis and Research*. Routledge, New York, NY.
- Loucopoulos, P. and Karakostas, V. (1995). *System Requirements Engineering*. McGraw-Hill, Berkshire, UK.
- Malone, T. W., Crowston, K., Pentland, B., Dellarocas, C., Wyner, G., Quimby, J., Osborn, C.S., Bernstein, A., Herman, G., Klein, M., O'Donnel, E. (1999). Tools for Inventing Organizations: Towards a Handbook of Organizational Processes. *Management Science*, 45(3), 425—433.
- Meyer B. (1985). On Formalism in Specifications. *IEEE Software*, 2(1), 6—26.
- Mylopoulos, J. (1992). *Conceptual Modelling, Databases and CASE: An Integrated View of Information Systems Development*. John Wiley & Sons Inc., New York, NY.
- Normann, R. and Ramirez R. (1994). *Designing Interactive Strategy – From Value Chain to Value Constellation*. John Wiley & Sons Inc., Chichester, UK.
- Osterwalder, A. and Pigneur, Y. (2002). An e-Business Model Ontology for Modeling e-Business. *Proceedings 15th Bled Electronic Commerce Conference*, Bled, Slovenia, 1-12.
- Pateli, A.G. and Giaglis, G.M. (2002). A Framework for Understanding and Analysing e-Business Models. *Proceedings 16th Bled eCommerce Conference*, Bled, Slovenia.
- Petrovic, O., Kittl, C., and Teksten, R.D. (2001). Developing Business Models for e-Business. *Proceedings of the International Conference on Electronic Commerce*. Vienna, Austria.
- Porter, M.E. (1980). *Competitive Strategy*, Free Press.
- Porter, M.E. (2001). Strategy and the Internet, *Harvard Business Review*, March-April, 63-78.
- Shama, A. (2001). Dot-coms' coma. *The Journal of Systems and Software*, 56(1), 101—104.
- Stabell, C.B. and Fjeldstad, O.D. (1998) Configuring value for competitive advantage: on chains, shops, and networks. *Strategic Management Journal*, 19, 413-437.
- Tapscott, D., Ticoll, D. and Lowy, A. (2000). *Digital Capital – Harnessing the Power of Business Webs*. Nicholas Brealy Publishing, London, UK.
- Uschold, M., King, M., Moralee, S. and Zorgios, Y. (1998). The Enterprise Ontology. *The Knowledge Engineering Review*, 13(1), 31—89.
- Wiegiers, K.E., (1999). *Software Requirements*, Microsoft Press, Redmond, WA

Ygge, F. and Akkermans, J. M. (1999). Decentralized Markets versus Central Control - A Comparative Study. *Journal of Artificial Intelligence Research*, October, 11, 301-333.